

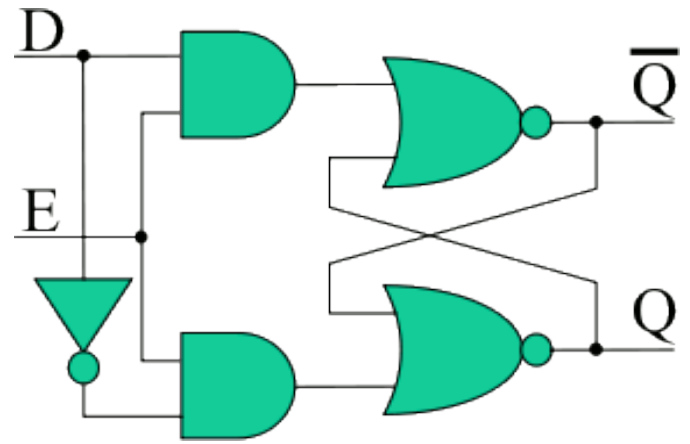



# D Latch

E	D	Q*	Command
0	x	Q	Remember
1	0	0	Transparent
1	1	1	Transparent



$$Q^* = DE + EQ$$

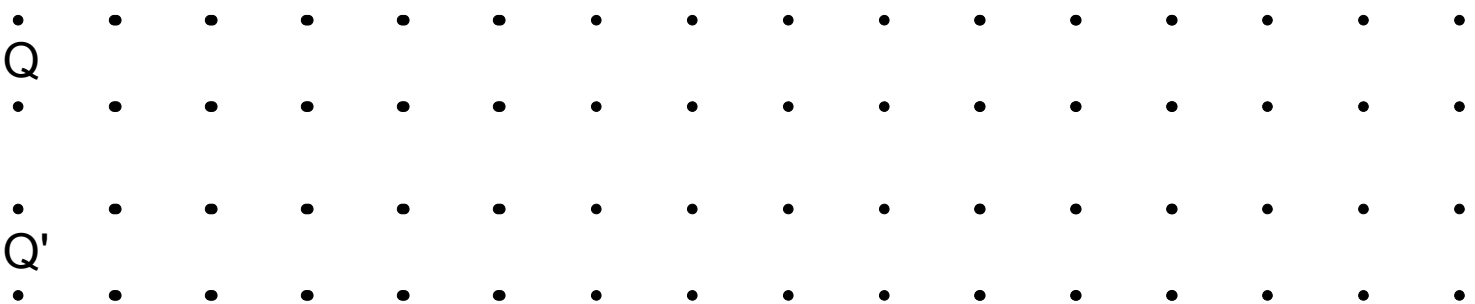
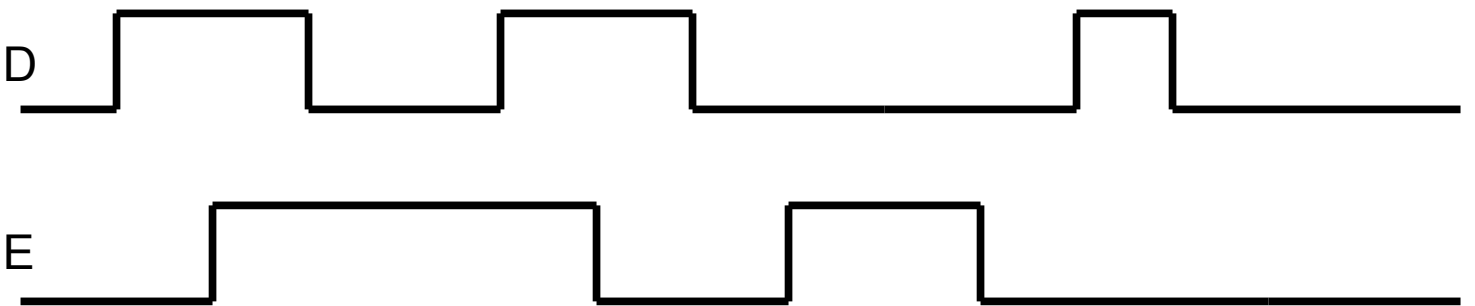
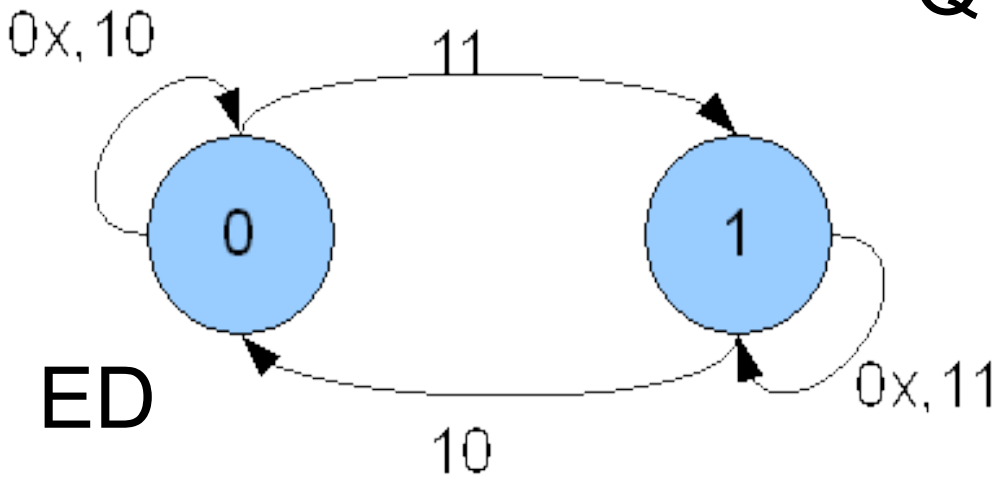

# D Flip-Flop

D	C	Q*	Command
0	↑	0	Reset
1	↑	1	Set

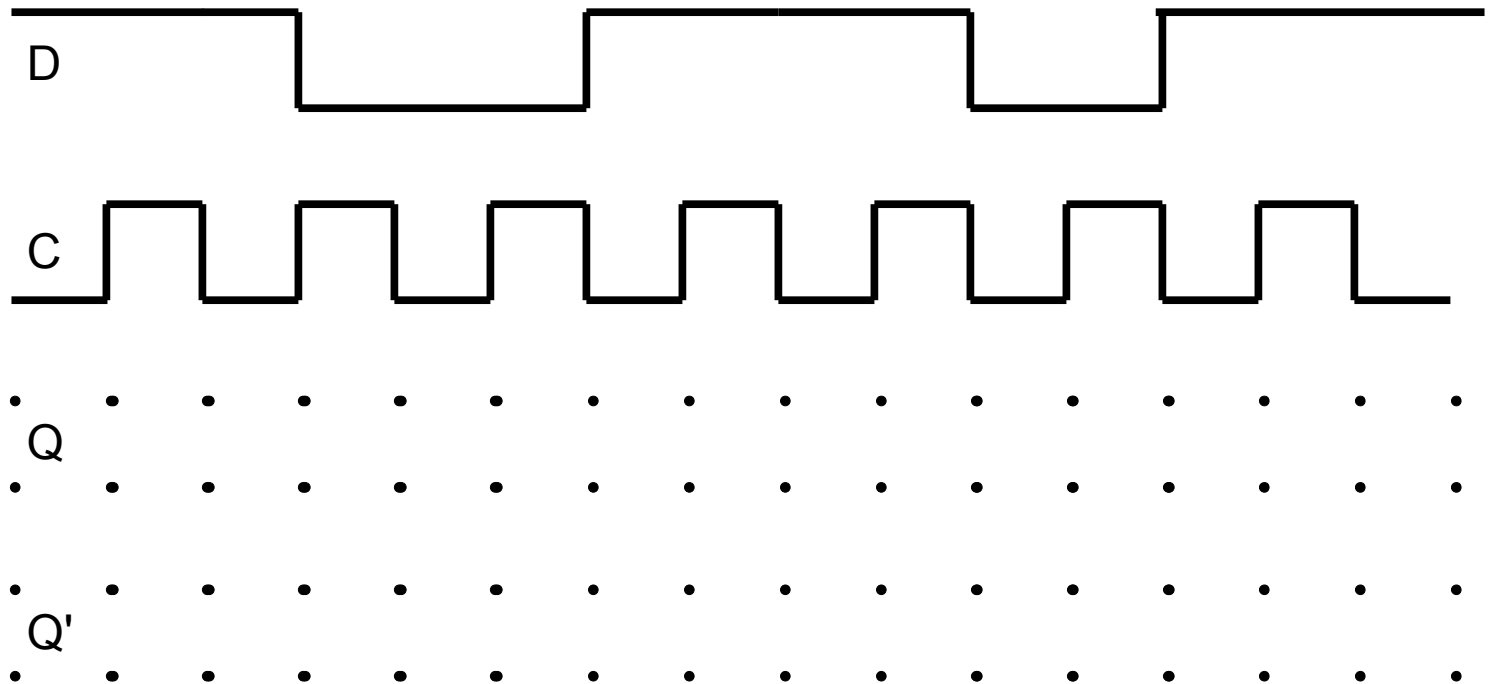
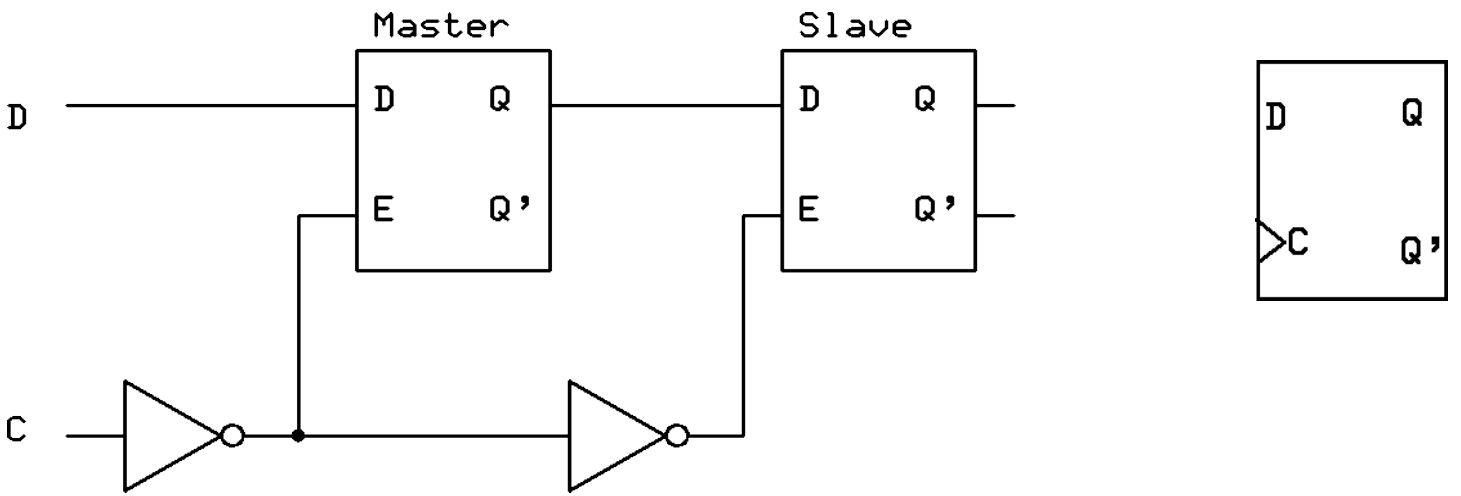
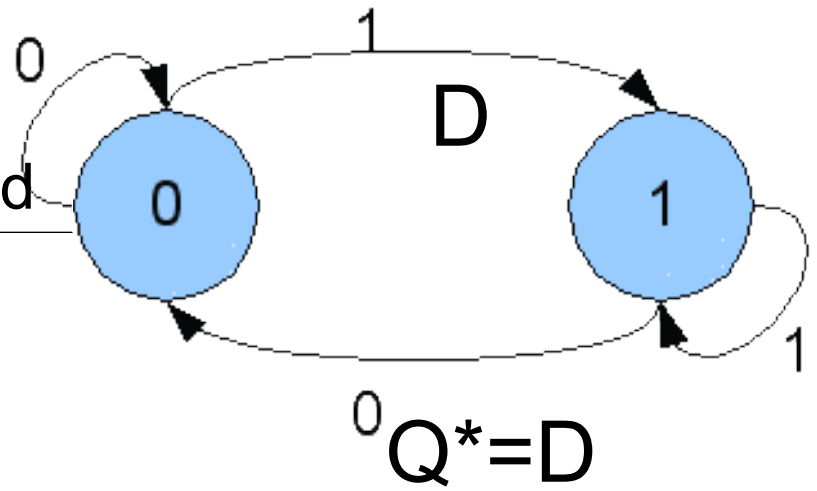



# T Flip-Flop (Edge Triggered)

T	Q*	Command
↓	Q'	Toggle

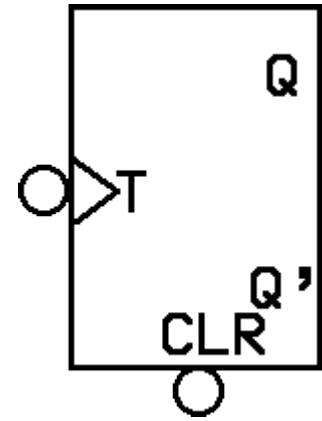

$$Q^* = \overline{Q}$$

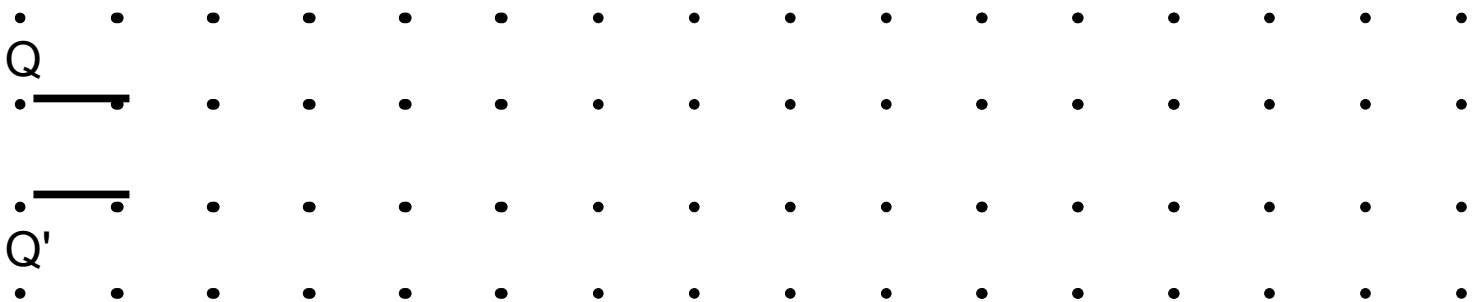
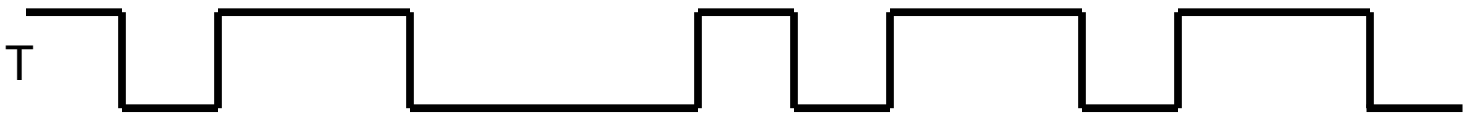
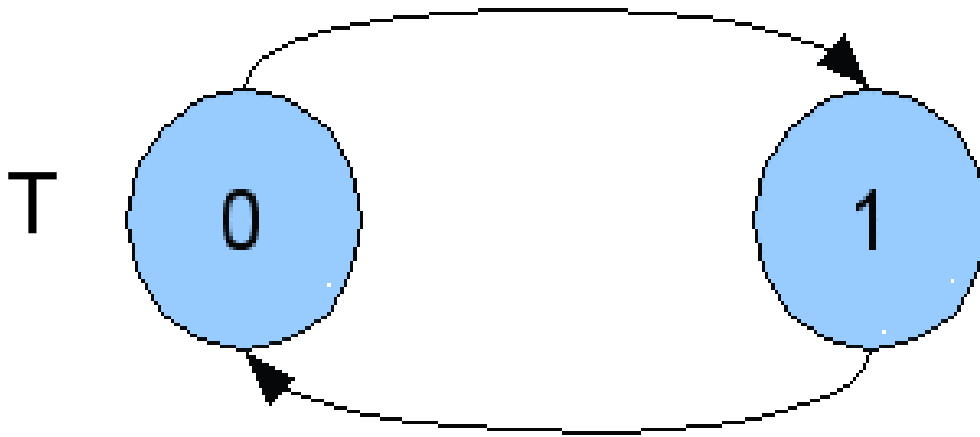

# T Flip-Flop (Clocked)

T	C	Q*	Command
0	↓	Q	Remember
1	↓	Q'	Toggle

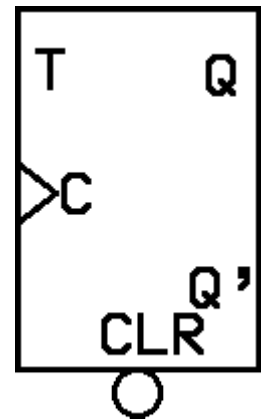

$$Q^* = TQ + TQ'$$

